



All Motors

INSTALLATION

4" Super Stainless — Dimensions

(Standard Water Well)

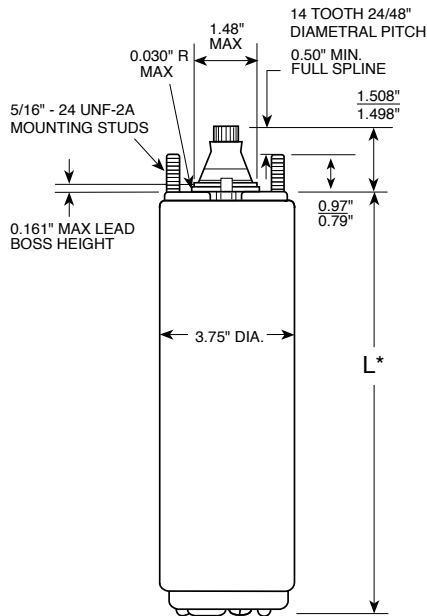

4" High Thrust — Dimensions

(Standard Water Well)

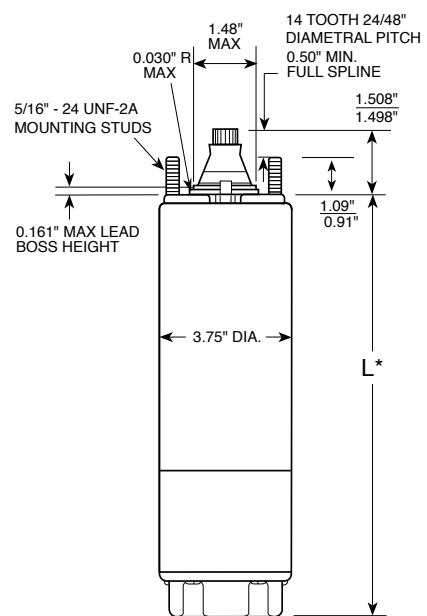

6" — Dimensions

(Standard Water Well)

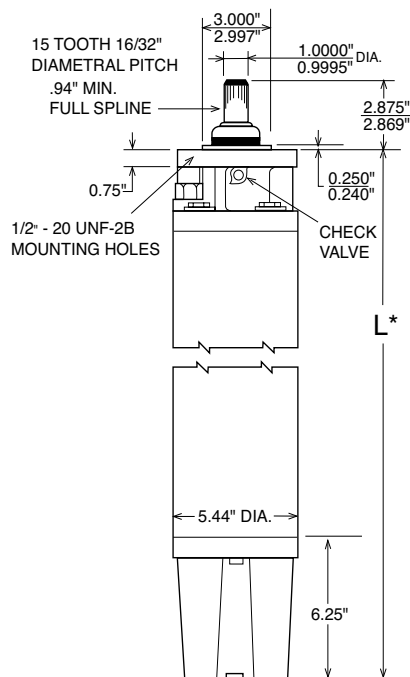

8" — Dimensions

(Standard Water Well)

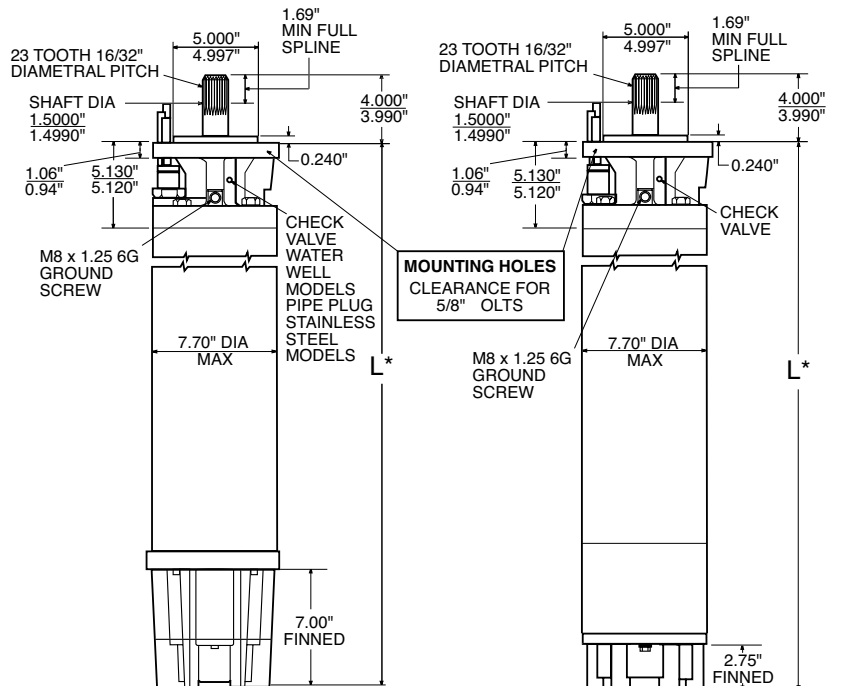

40 to 100 hp

75 to 200 hp

* Motor lengths and shipping weights are available on Franklin Electric's web site (www.franklin-electric.com) or by calling Franklin's Technical Service Hotline (800-348-2420).