

# Duplex Inline Constant Pressure System

## Typical Install Guide

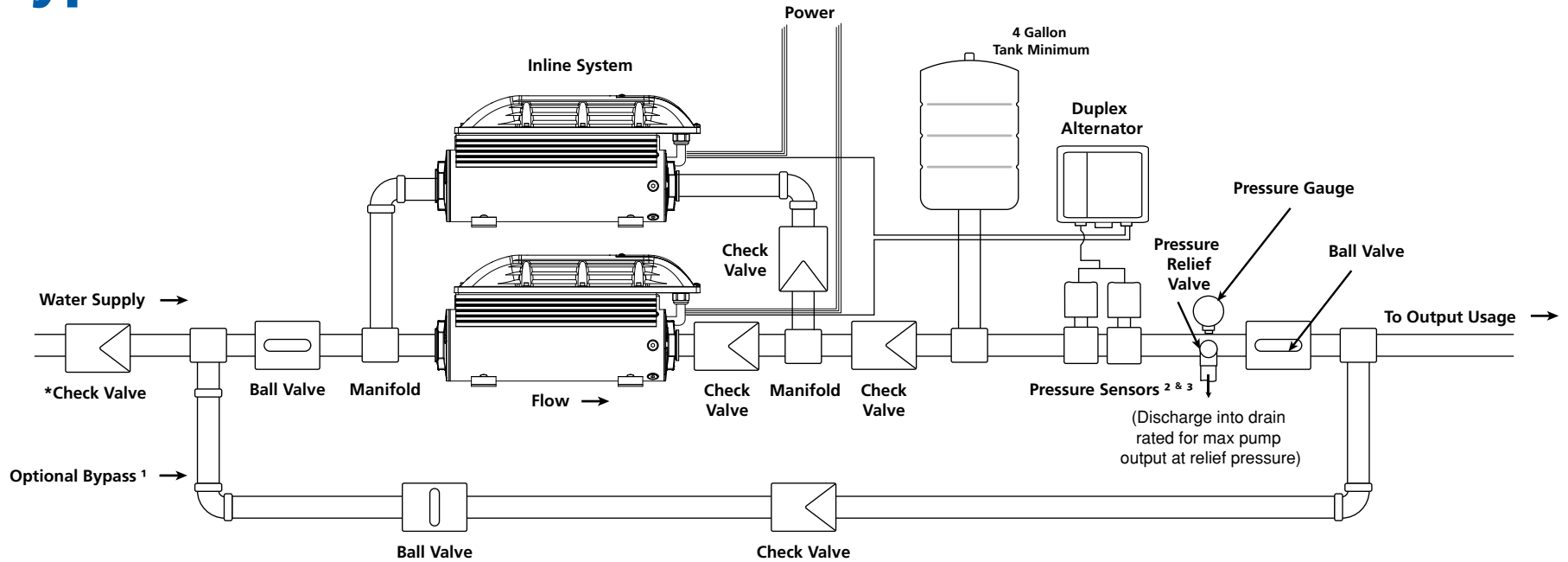

**\*NOTICE:** If system plumbing does not have a backflow prevention device a check valve is required on the incoming water supply line.

### NOTES:

1. These optional components are shown in a typical installation diagram. They should be used at the installer's discretion as required for particular applications.
2. If the optional high pressure shut-off kits (305707912) are being used on this duplex Inline Constant Pressure System, they should be installed as per the standard Inline Constant Pressure System Owner's Manual, with one high pressure cut-off being wired directly to each Inline drive unit.
3. 3 PSI differential required between these two sensors for proper operation of the system. Prior to wiring any components, lower the pressure setting in one of the sensors. This is done by turning the hex pressure adjustment screw on the top of the switch by at least 1/4" turn counter clockwise (or 3 psi).

## Dimensions

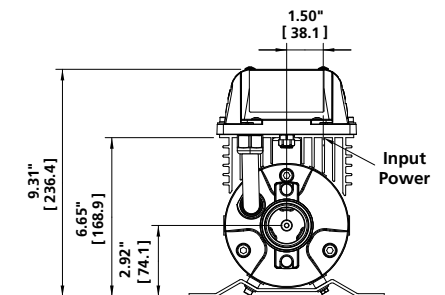
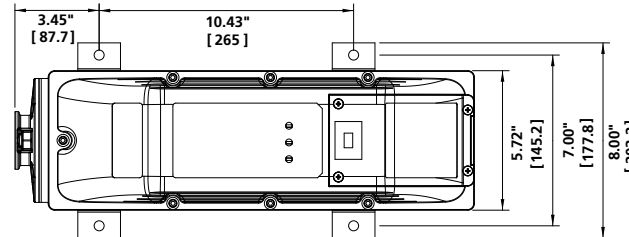
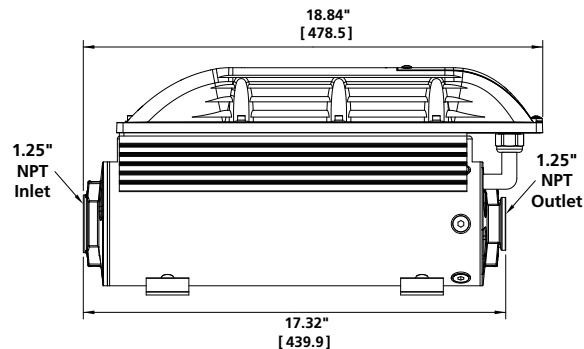

# Duplex Inline Constant Pressure System Wiring Guide

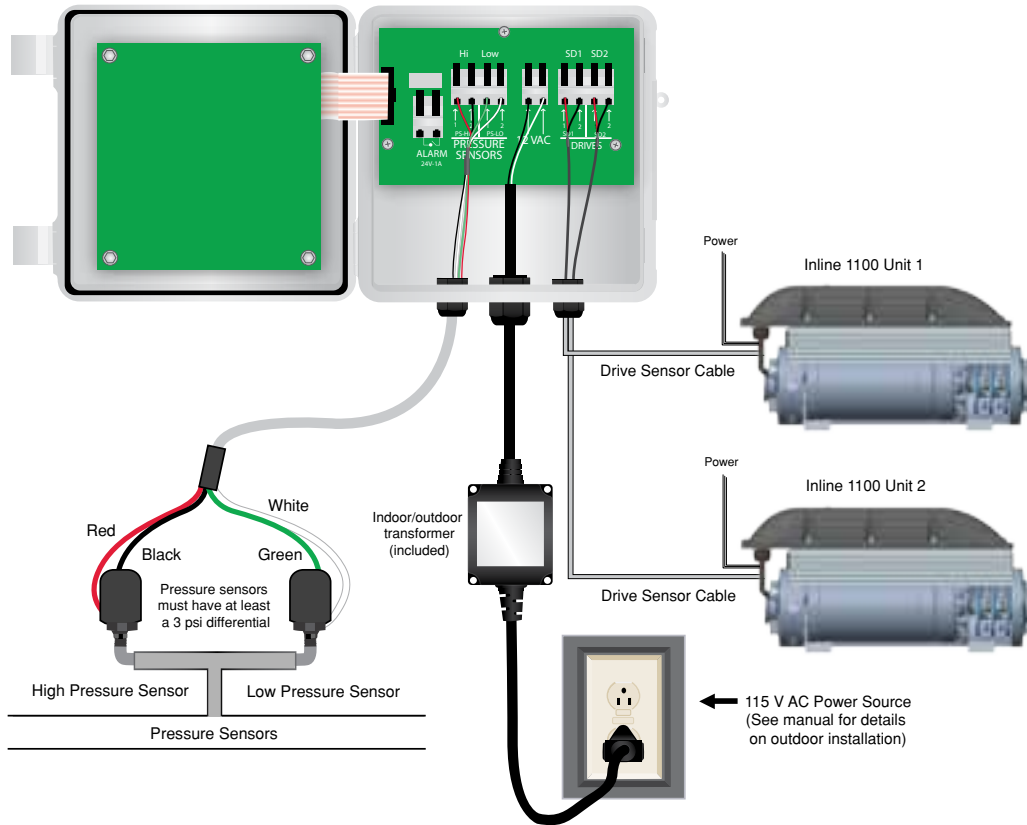

## STEP 1

Prior to wiring the duplex alternator, or the Inline CP systems, adjust the low pressure sensor by turning the hex pressure adjustment screw at least 1/4 inch turn counter clockwise (or 3 psi).



**Franklin Electric**

9255 Coverdale Road, Fort Wayne, IN 46809  
Tel: 260.824.2900 • Fax: 260.824.2909

[www.franklin-electric.com](http://www.franklin-electric.com)

M2071 3/14

## STEP 2

### Pressure Sensor Connections

Connect the ends of the four-conductor cable with the spade terminals to the two pressure sensors.

Connect the red and black wires to the high pressure sensor. Connect the stripped ends of the red and black wires to the alternator (PS-HI). The red and black wire connections are interchangeable.

Connect the green and white wires to the low pressure sensor. Connect the stripped ends of the green and white wires to the alternator (PS-LO). The green and white wire connections are interchangeable.

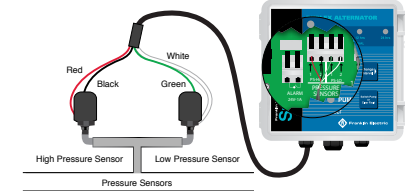

## STEP 3

### Connecting the Inline 1100 to the Alternator

#### Instructions:

Use the pressure sensor cable that came with the drive unit. Cut off the fork terminal ends and strip wires to 1/4 inch (Figure 1).

Connect one end to the drive's pressure sensor terminals (Figure 2) and one end to the alternator's drive input terminals (Figure 3, labeled SD1 or SD2).

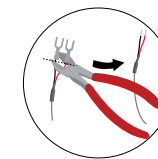

Figure 1

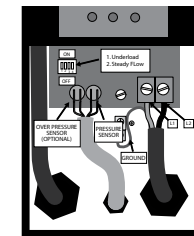

Figure 2:  
Inline internal wiring

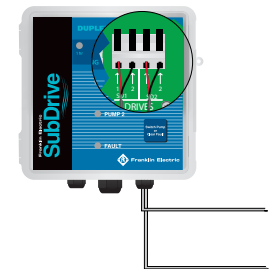

Figure 3:  
Drive cable connection